



SEIMS Portal app



SEIMS Portal website
www.seims-portal.com



SolarGo app



Company's official website



Company Wechat



MT Series User Manual

GoodWe(China)

No.189 Kunlunshan Rd., SND,
Suzhou, 215163, China
T: 400 998 1212
service.chn@goodwe.com.cn
www.goodwe.com.cn

GoodWe(Netherlands)

Zevenwouden 194 ,
3524 CX Utrecht, the Netherlands
T: +316 1988 6498
service.nl@goodwe.com.cn
www.goodwe.com.cn

GoodWe(Australia)

19 Fairleigh Street, Glenroy,
VIC, 3046, Australia
T: +613 9324 0559
service.au@goodwe.com.cn
www.goodwe.de

GoodWe(UK)

46 Foyle Road London
N17 ONL United Kingdom
T: + 44 (0)333 358 3184
service@goodwe.co.uk
www.goodwe.com.cn



SOLAR INVERTER

1 Safety and warning	01
-----------------------------------	----

2 Product introduction	01
2.1 Intended usage	02
2.2 Inverter Overview	03
2.3 Technical description	05
2.4 Package	06

3 Mounting	08
3.1 Mounting instruction	08
3.2 Equipment Installation	08
3.3 Electrical Connection	11
3.4 Communication connection.....	14













4 System Operation	17
4.1 User Interface and Controls	17
4.2 WiFi Reset & WiFi Reload	22
4.3 system operation	23
4.4 Error code	23

5 Troubleshooting	23
5.1 Overvoltage category definition.....	25
5.2 Moisture location category definition.....	25
5.3 Environment category definition	25
5.4 Pollution degree definition	25

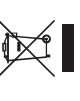
6 Technical parameters and block diagram	
6.1 Technical parameters	26
6.2 Block Diagram	29

7 Maintenance	31
7.1 Clearing the FAN	31
7.2 Checking the DC Switch	31
7.3 Checking the Electrical Connection	32
7.4 Fuse Replacement	32

8 Relevant Certification	32
---------------------------------------	----

	There is a risk of injury due to improperly handle the device.		Component of product can be recycled
	Danger of high voltage and electric shock.		This surface is upward, and it should not be tilted and upended.
	Danger of hot surface! Do not touch the hot surface when the device is running.		No more than four (4) identical packages be stacked on each other
	Product should not be posed as normal house hold waste.		The package/product should be handled carefully and never be tipped over or slung.
	Refer to the operating instructions		Keep Dry
	 5min		CE mark.

This symbol indicates that you should wait at least 5mins after disconnecting the inverter from the utility grid and from the PV panel before touching any inner live parts.

1 Safety and warning

This manual contains important instructions for MT series inverter that shall be followed during installation and maintenance of the inverter.

The MT series for Four-MPPT, Three-Phase solar inverter without transformer, which consists of GW50K-MT, GW60K-MT, GW50KN-MT, GW60KN-MT, GW50KBF-MT, GW60KBF-MT, GW70KHV-MT and GW80KBF-MT model type.

MT Series have been designed and tested strictly according to the international safety regulation. As electrical and electronic equipment, safety instructions related to them must be complied with during installation, commissioning, operation and maintenance. Incorrect or work may result in damage to:

1. The life and well-being of the operator or a third party.
 2. The inverter and other properties that belong to the operator or a third party. Therefore the following safety instructions must be read and always kept in mind prior to any work. All detailed work-related safety warnings and notes will be specified at the critical points in corresponding chapter. All installation and electrical work must only be performed by qualified personnel. They have:
 - Been trained specially;
 - Already completely read through and understood the manual and related documents.
 - Be familiar with safety requirements for electrical systems.
- The inverter must be installed and maintained by professionals in compliance with local electrical standards regulations and the requirements of local power authorities or companies.
- There is a risk of injury due to improperly handling device.
 - Always follow the instructions contained in the manual when moving or positioning the inverter.
 - The weight of the equipment can cause injuries, serious wounds or bruise if improperly handled.
 - Please install it in the place beyond children's reach.
 - Prior to installing and maintaining the inverter, it is crucial to make certain that the inverter is not electrically connected.

- Before maintaining the inverter, disconnect the connection between the AC grid and the inverter firstly, and then disconnect the connection between the DC input and the inverter, you should wait at least 5mins after these disconnection in case of electric shock.
- All cables must be firmly attached, undamaged, properly insulated, and adequately dimensioned.
- The temperature of some parts of the inverter may exceed 60°C during operation. To avoid being burnt, do not touch the inverter during operation. Let it cool before touching it.
- Without permission, it is not allowed to open the front cover of the inverter. Users should not touch/replace any components of the inverter except the DC/AC connectors. GOODWE will not bear any consequences caused by unauthorized actions which will lead to potential injury to people and damage to inverters.
- Static electricity may damage electronic components. Appropriate method must be adopted to prevent such damage to the inverter; otherwise the inverter may be damaged and the warranty will be annulled.
- Ensure that the output voltage of the proposed PV array is lower than the maximum rated input voltage of the inverter; otherwise the inverter may be damaged and the warranty will be annulled.
- If the equipment is used in a manner not specified by the manufacturer, the protection provided by the equipment may be impaired.
- When exposed to sunlight, the PV array will generate very high voltage which can cause electrical shock hazard. Please strictly follow the instruction we provided.
- PV modules should have an IEC61730 class A rating.
- Prohibit inserting or pulling the AC or DC terminals when the inverter is working. Or the inverter will be destroyed. Only DC connectors provided by GoodWe are permitted to use, otherwise the inverter may be damaged and the warranty will be annulled.
- The inverter can exclude the possibility of DC residual currents to 6mA in the system, Where an external RCD is required in addition to the built-in RCMU, type A RCD must be used to avoid tripping.
- The default photovoltaic module is not grounded.
- If there are more than 3 PV strings on input side, an additional fuse installing will be suggested.

⚠ The IP65 premise is that the machine is completely sealed. Please install it within one day after unpacking, otherwise please block the unconnected port and do not open it to ensure that the machine is not exposed to water and dust.

2 Product introduction

2.1 Intended usage

The MT series which is a Four MPPT, three phase transformer-less grid-connected inverter is a crucial unit between the PV string and the utility grid in the PV power system.

Inverter is dedicated to converting directing current generated by the PV modular into alternating current, which conforms to parameters to local utility grid and fed it into the utility grid. The intended usage of inverter is illustrated in figure 2.1-1.

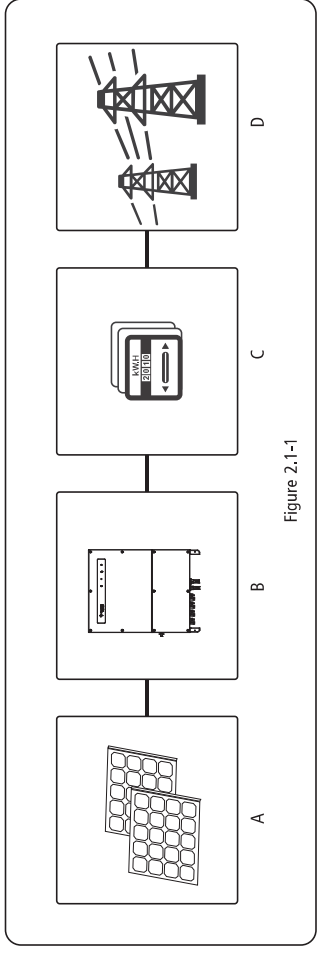

Figure 2.1-1



The inverter cannot be connected to the PV module that the positive or negative terminal of which should be grounded. Excepting a transformer has been used between inverter and grid.

Item	Description	Note
A	PV string	Monocrystalline silicon, polycrystalline silicon and else.
B	Inverter	MT Series
C	Meter device	Meter cupboard with distributed generation system
D	Utility grid	TN-S, TN-C, TN-C-S, TT, IT (different Model types with different types of utility grid as below)

Note:

MT series GW50KN-MT, GW60KN-MT, GW50KBF-MT, GW60KBF-MT support four different types of grid. please refer to Figure 2.1-2

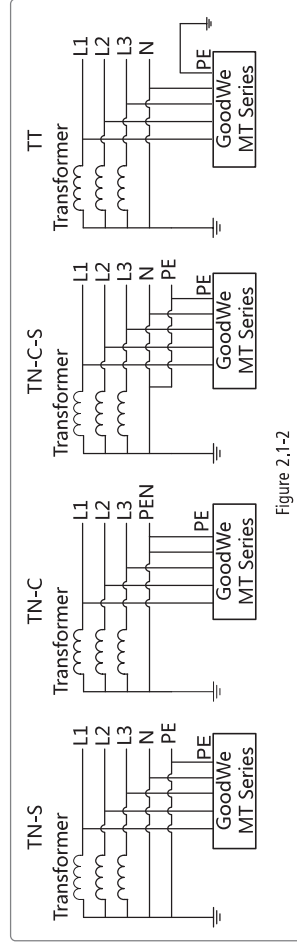

Figure 2.1-2

Note :

For TT grid structure, RMS voltage between neutral wire and earth wire must be less than 20V.

GW70KHV-MT, GW80KHV-MT and GW80KBF-MT support IT grid type. Please refer to Figure 2.1-3.

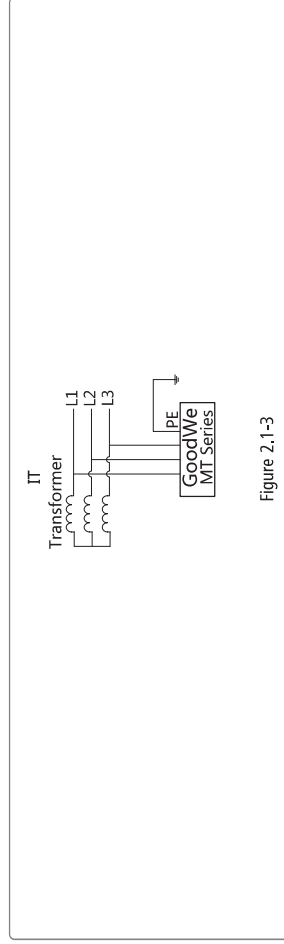

Figure 2.1-3

2.2 Inverter Overview

2.2.1 Inverter Overview

MT Series inverter illustration.

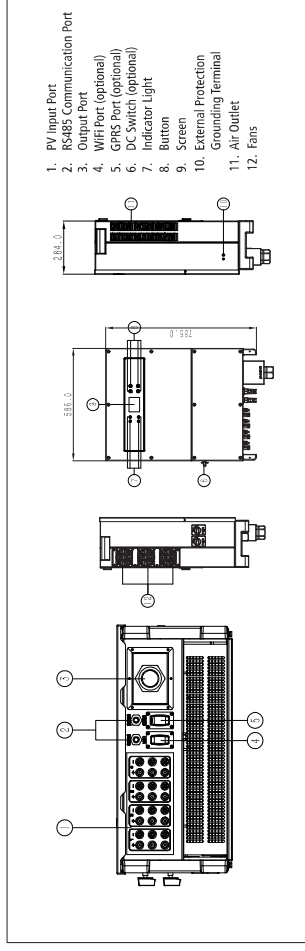
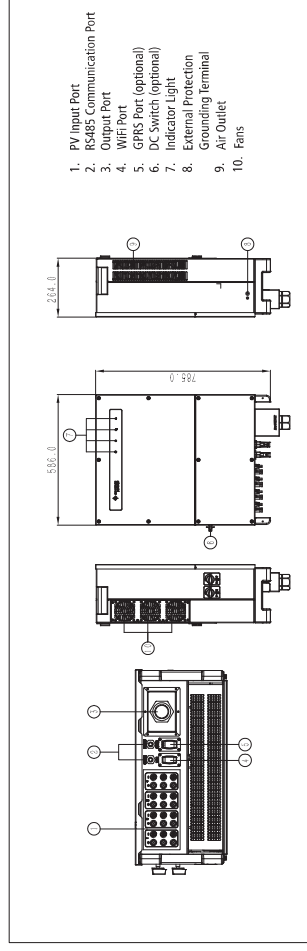

Image shown here is for reference only, actual product you receiver may differ.



2.2.2 LCD panel and LED

As a human-computer interaction interface, LCD display panel comprise LED indicators, buttons and LCD display on the front panel of the inverter.

LED indicates the working status of the inverter.

Buttons and LCD are used for configuration and viewing parameters.

LCD panel For GW50K-MT, GW60K-MT, GW50KN-MT, GW60KN-MT, GW50KBF-MT, GW60KN-MT, GW70KHV-MT, model type.

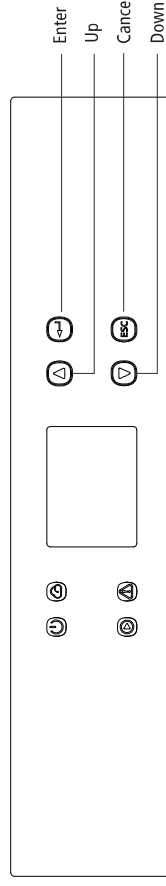

LED only for GW60KBF-MT, GW80KHV-MT, GW80KBF-MT model type.



Green / green / green / red light respectively correspond to: / / / /

INDICATOR	STATUS	EXPLANATION
		ON=EQUIPMENT POWER-ON
		OFF=EQUIPMENT POWER-OFF
		ON=INVERTER IS FEEDING POWER
		OFF=INVERTER IS NOT FEEDING POWER
		SINGLE SLOW FLASH=SELF CHECK BEFORE GRID CONNECT
		SINGLE FLASH=WILL CONNECT WITH GRID
		ON=WIRELESS CONNECTED/ACTIVE
		BLINK 1=WIRELESS SYSTEM RESETING
		BLINK 2=WIRELESS ROUTER PROBLEM
		BLINK 4=WIRELESS SERVER PROBLEM
		BLINK =RS485 CONNECTED
		OFF =WIRELESS NOT ACTIVE
		ON =FAULT OCCURRED
		OFF =NO FAULT

2.2.3 DC Switch

The DC switch is designed for safely disconnecting DC input if required.

The inverter works automatically when the input and output meet the requirements. Rotating the DC switch to "OFF" position will immediately cut off the flow of DC current.

Rotate the DC switch to "ON" position before starting the inverter.

2.3 Technical description

2.3.1 principle description

PV string voltage is transmitted to DC BUS via BOOST circuit.

The MT series is equipped with four MPPTs for four DC inputs to ensure that the maximum power is utilized even in different PV installation condition.

DC/AC converter circuit convert DC power into AC power, which can be fed into the utility. Protective circuit are designed to protect the inverter safety and human safety.

DC switch is integrated for safely disconnect the DC input. The inverter provides standard interface RS485, USB, WIFI(optional) for communication. Inverters also provide running recode data display, parameter configuration via LCD panel or APP.

The main block diagram please refer to chapter 6.2.

2.3.2 Function description

Inverter functions can be grouped as following.

- Conversion function

Inverter converts direct current power into alternating current power, which conforms to the grid requirement of its installation country.

- Data storage and display

Inverter stores the running information and fault records and display them on the LCD screen or APP.

- Parameter configuration

Inverter provides various parameter configurations for optional operation.

- Communication interface

Inverter provides standard RS485 communication interface, also USB, WIFI(optional) can be provided.

- Protection functions

> Insulation resistance to ground surveillance.

> Input voltage monitor

> Residual current monitoring unit

> Anti-islanding protection

> PV array string fault monitoring

> DC fuse

> DC switch

> DC SPD

> AC SPD

> SPD fault monitoring

> AC over current protection

> Insulation monitoring

2.4 Package

2.4.1 Unpacking and inspection

The unit is thoroughly tested and strictly inspected before delivery. Damage still be occur during shipping.

1. Check the packing for any visible damage upon receiving.
2. Check the inner contents for damage after unpacking.
3. Check the package list below.

Package list

WiFi Connection Configuration (WiFi model only)

SolarGo app (NO LCD in display only)

*Positive DC plug: 50KBF 8pairs, 50kW 10pairs, 60kW/60KBF/70kW/80KBF 12pairs, 80kW 16pairs
 *Negative DC plug: 50KBF 8pairs, 50kW 10pairs, 60kW/60KBF/70kW/80KBF 12pairs, 80kW 16pairs

2.4.2 Identify the inverter

A nameplate is attached to one side of the inverter. It provide information on type inverter, along with the most important specifications, marks of certifications, website and serial number, which is available and identified by Goodwe.

Nameplate of Connected PV Inverter	
Type	GW70KHV-WT
Max. DC input power	110.0kW
Max. PV	41.5kW/501.5kW/50kW
Rated DC Voltage	750Vdc
Rated DC Current	146.67A
Max. DC current	150.00A
Rated AC Voltage	SAPE = 640V
Max. AC current	88A
AC input frequency	50/60Hz
Max. apparent power	77kVA
Power factor	Non-constant
Operating temperature range	-40...85°C
Storage temperature range	-30...60°C
AC overvoltage category	Category III
DC overvoltage category	Category II
IP degree	IP65
Protection class	IP65
CE mark	CE
RoHS mark	RoHS
UL mark	UL
VDE mark	VDE
AS/NZS mark	AS/NZS
IEC mark	IEC
CSA mark	CSA
AS/NZS 4772.2:2015, IEC 61727	
VDE-AR-N 4105, VDE 0196-41, GB3093, EN 60438	
SIN:	
14-16-52-020-7160 Email: info@goodwe.com 4000183394 Fax: Sales@goodwe.com	

Image shown here is for reference only, actual product you receive may differ.

Item	Description
1	Logo and inverter type
2	Technical data of inverter
3	Marks of certification institution of inverter
4	S/N No. and Company name, website and origin

3 Mounting

3.1 Mounting instruction

In order to achieve optimal performance, the ambient temperature should be kept lower than 45 °C. For the convenience of checking the LCD display and possible maintenance activities, please install the inverter at eye level. Product label and warning symbol shall be clearly visible after installation. Please do not install inverter under direct sunlight, rain and snow.

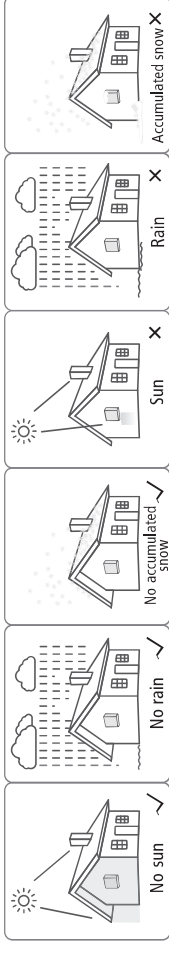

3.2 Equipment Installation

3.2.1 Selecting the installation location

Take the load capacity of the wall into account. The wall (such as concrete wall and metal structure) should be strong enough to hold the weight of the inverter over a long time. Install the unit where is accessible to install, electrical connect or service. Do not install the unit on the wall of flammable material. Make sure the installation location is well ventilated. Inverters should NOT be installed near inflammable or explosive items. Any strong electro-magnetic equipment should be kept away from installation site.

Installation the unit at eye level for easily buttons operation and display Read

Carry out the installation vertically or tilt backward no more than 15 degrees, no lateral tilt, and wiring area should be downward, which is shown in Figure 3.2.1-1.

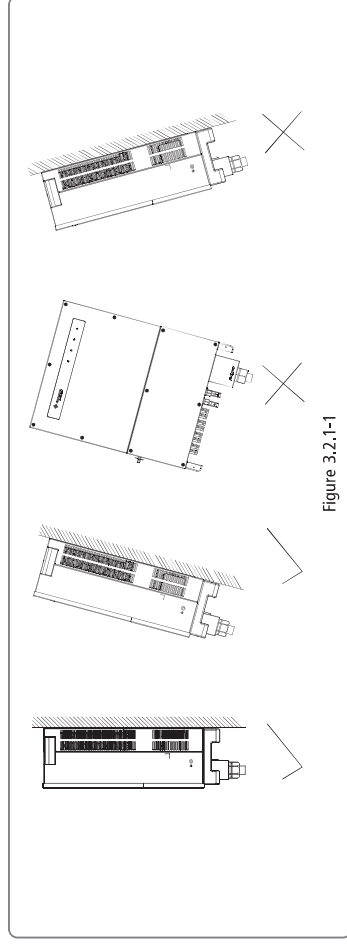
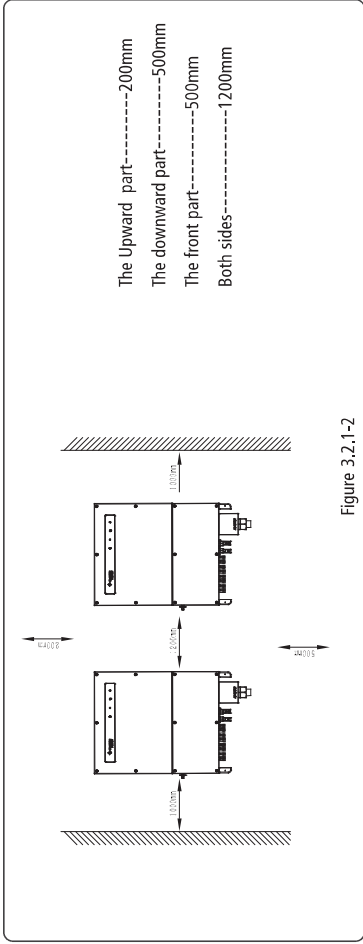

Figure 3.2.1-1

To ensure the good heat dissipation and convenient disassembly, the minimum clearance around the inverter should not be less than the following values, which are shown in figure 3.2.1-2



3.2.2 Mounting Procedure

- (1) Use the wall-mounted bracket as a template and drill 6 holes on the wall, 13 mm in diameter and 65 mm deep.
The inverter sizes of MT series please refer to Figure 3.2.2-1.
- (2) Fix the wall mounting bracket on the wall with six expansion bolts in accessory bag in Figure 3.2.2-2.
- (3) Carry the inverter with the handles on both sides of the inverter of MT series, which is shown in Figure 3.2.2-3.
- (4) Place the inverter on the wall-mounted bracket as illustrated in Figure 3.2.2-4, 3.2.2-5

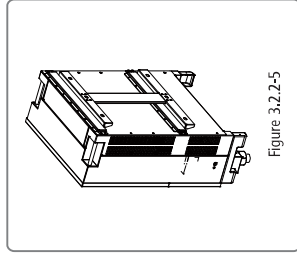
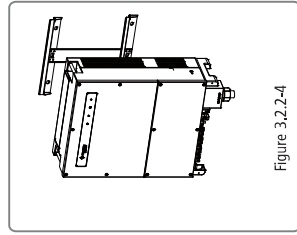
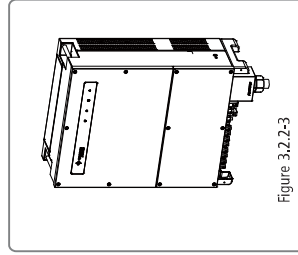
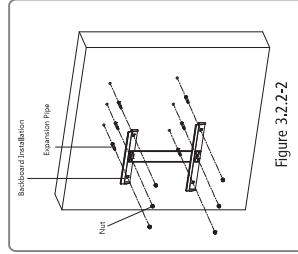
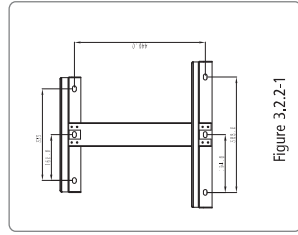

3.2.3 Schematic Diagram Of Cover Dismantling and Installation Steps

1. Dismantle the downside cover (Tool: external hexagonal screwdriver);
2. Electrical installation;
3. Assemble bottom side cover (Material: M4 stainless steel nuts. Tool: allen screwdriver);
4. Assemble bottom side cover (Material: M4 stainless steel nuts. Tool: cross screwdriver);
5. Assemble downside cover (Tool: external hexagonal screwdriver. Twisting Force: 2N.m).

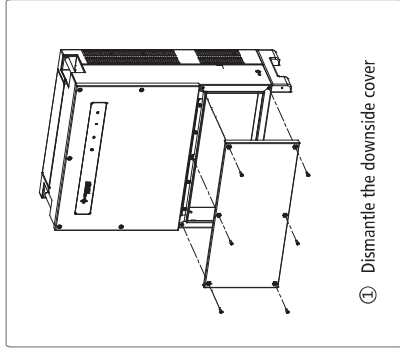

② Electrical installation

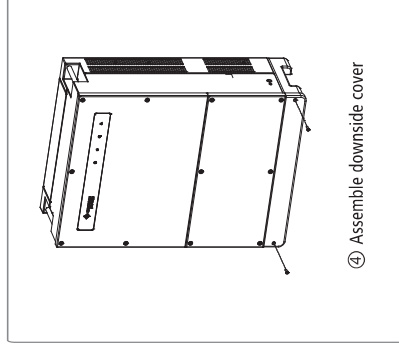
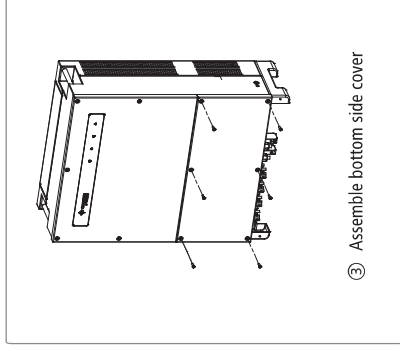

3.3 Electrical Connection

3.3.1 Connection to Grid (AC Side Connection)

- (1) Measure the voltage and frequency of grid-connected access point, and make sure it is accordance with the grid-connected standard of inverter.
- (2) It is recommended to add breaker or fuse to AC side, the specification should be more than 1.25 times of rated of AC output current.
- (3) The PE line of inverter should be connected to the earth, make sure that the impedance between the neutral wire and earth wire is less than 10 ohm.
- (4) Disconnect the breaker or fuse between the inverter and the utility.
- (5) Connect the inverter to the grid as follows:
 - (6) Fix (Torque: 6~8 N.m) the connector of AC cable to the corresponding terminals
 - (7) Neutral conductor shall be blue, line conductor shall be black or brown (preferred), protective earth bonding line shall be yellow-green.
 - (8) The AC line construction shall be such that if the cord should slip in its anchorage, placing a strain on conductors, the protective earthing conductor will be the last to take the strain. such as the PE line is longer than L and N.

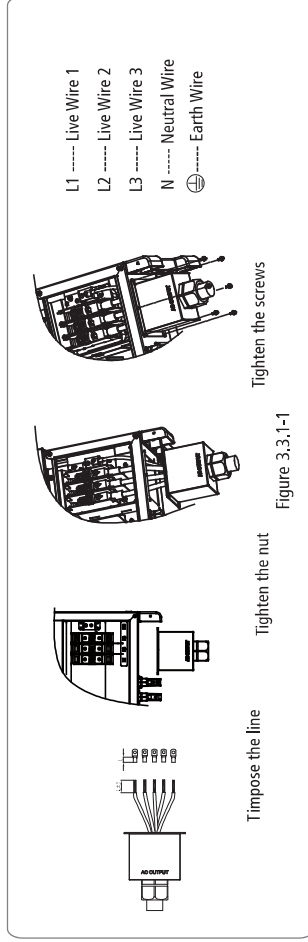

Note: There is no need to connect the Neutral wire to the inverter for GW70KHV-MT, GW80KHV-MT and GW80KBF-MT products

AC cable illustration please refer to Figure 3.3.1-2.

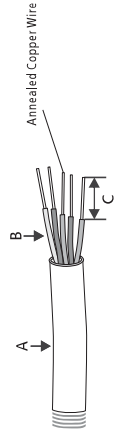

Grade	Description	Value
A	O.D	30~38mm
B	Section area of conductor material (mm ²)	25~95mm ²
C	Length of Bare wire	According to the terminal length

Figure 3.3.1-2

3.3.2 AC circuit breaker and residual current protection device

An independent three or four pole circuit breaker for each inverter must be installed at the output side to ensure that the inverter can be securely disconnected from the grid.

The output current of GW50K-MT, GW50KN-MT is 80A, so we recommend that the nominal current of the AC breaker is 100A.

The output current of GW60K-MT, GW60KN-MT, GW60KBF-MT, GW70KHV-MT, GW80KHV-MT and GW80KBF-MT is 90A, so we recommend that the nominal current of the AC breaker is 120A.



Note: It's not allowed for several inverter to use the same circuit breaker.

It's not allowed to connect loads between inverter and circuit breaker.

The internal integrated residual current detection device (RCD) of inverter can detect external leakage current in real time, when detecting the leakage current value exceeds the limit value, the inverter will be disconnected from the grid as soon as possible. If an external RCD is installed, the action current should be 500mA or higher.

3.3.3 Earth terminal connection

The inverter is equipped with earth terminal according to the requirement of EN 50178.

All non-current carrying exposed metal parts of the equipment and other enclosures in the PV power system should be grounded. Please connect 'PE' cable to ground.

1. Strip the wire insulation sheet of a suitable length with a wire stripper, illustrated as Figure 3.3.3-1.

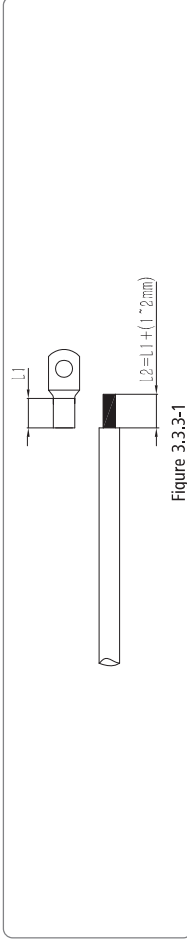

2. Insert the stripped wire into the terminal and compress it tightly by crimping pliers, illustrated as Figure 3.3.3-2.

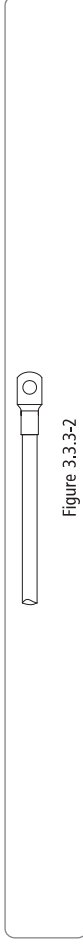

3. Fix the earth wire on the machine, illustrated as Figure 3.3.3-3.

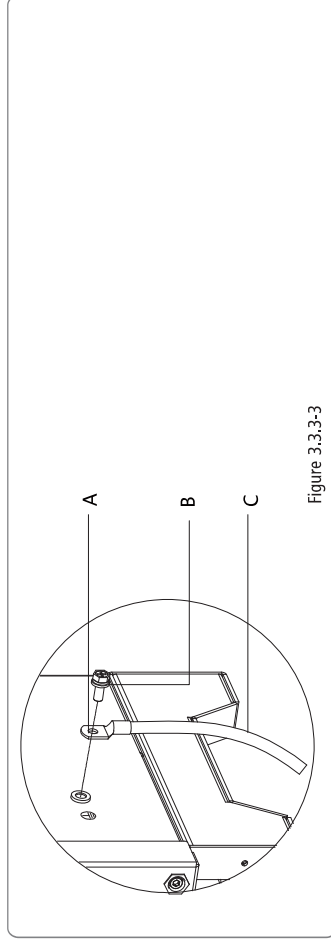

Figure 3.3.3-3

4. In order to improve the corrosion resistance of the terminal, it is recommended to apply silica gel on the earth terminal for the corrosion protection after the grounding cable assembly is completed.

3.3.4 Connecting inverter to PV panel



Caution

Make sure the DC switch is turned off before connecting PV string to the inverter.
 Make sure PV string polarity confirms with DC connector, otherwise, it will cause damage to inverter.
 Make sure the maximum open circuit voltage (Voc) of each PV string does not exceed the maximum input voltage of the inverter under any condition(1100V).
 Make sure that the maximum short circuit current of each DC input is less than the inverter allowable limit.
 Do not connect positive or negative pole of PV string to earth (PE terminal). Otherwise, it will permanently destroy the inverter.
 Positive shall be red, negative shall be black .
 The minimum insulation resistance to ground of the PV panels must exceed 33.3kΩ (R = 1000/50 mA), there is a risk of shock hazard if the requirement of minimum resistance is not met.
 The MT series has four PV input area PV1 input, PV2 input, PV3 input, PV4 input, each with MPP tracker. The four PV input works independently, therefore the four PV input can be different with each other, including different type of modular, different numbers of connecting PV strings, different orientation angel of PV modular.
 The installation method of DC connector is shown in Figure 3.3.4-1.

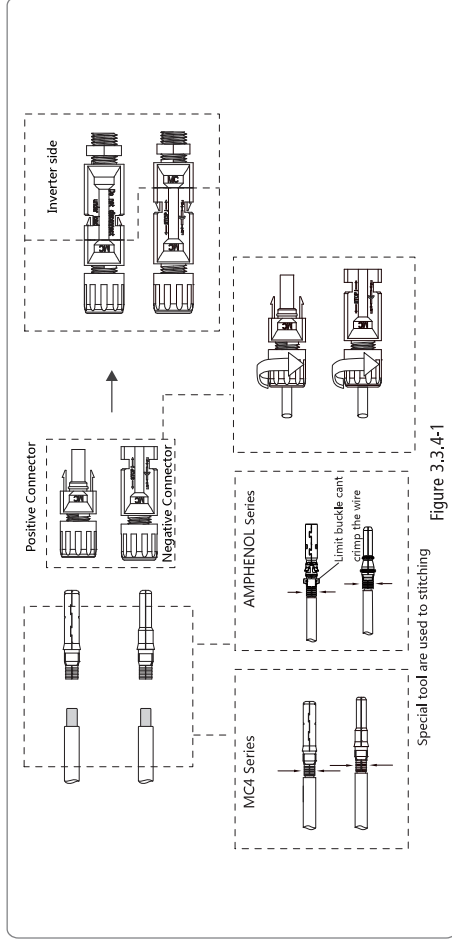

Figure 3.3.4-1

DC Cable specification please refer to Figure 3.3.4-2.

Label	Description	Value
A	External diameter of wire stock	4~5mm
B	Cross-sectional area of conductor material	2.5~4mm ²
C	Length of bare wire	About 7mm

Figure 3.3.4-2

In order to make the internal inverter better dustproof and waterproof, all the DC connectors provided by accessory bag should be connected to the inverter, if only some of the DC connectors are used, the DC connectors without connection should be blocked with non-conductive insulator.

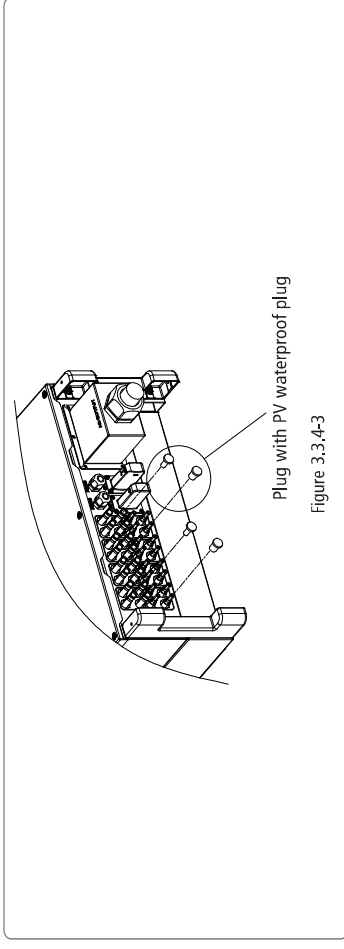

Plug with PV waterproof plug

Figure 3.3.4-3

3.4 Communication connection

Inverter operation data can be transferred by USB, RS485, or WIFI Modular to a PC with monitoring software or to data logger device such as Ezlogger Pro. USB just used for service debug; RS485 is the standard communication choice for inverter, and WIFI modular can be used optionally for communication.

3.4.1 USB connection

USB cable must be connected according to the following steps, which are as shown in Figure 3.4.1-1.

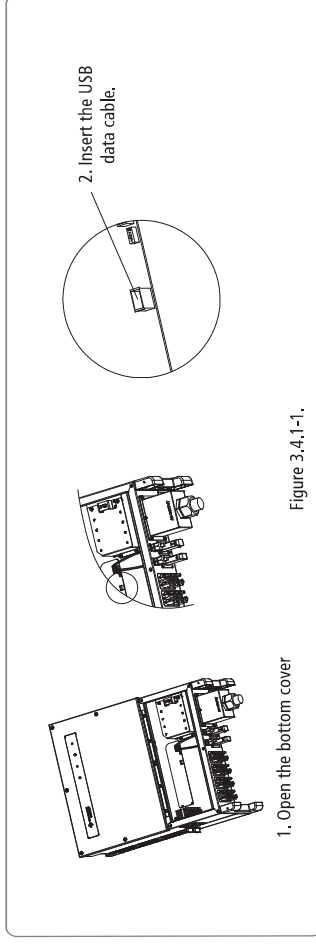

Figure 3.4.1-1.

USB cable must be connected according to the following steps For GW80KHV-MT&GW80KBF-MT, which are as shown in Figure 3.4.1-2.

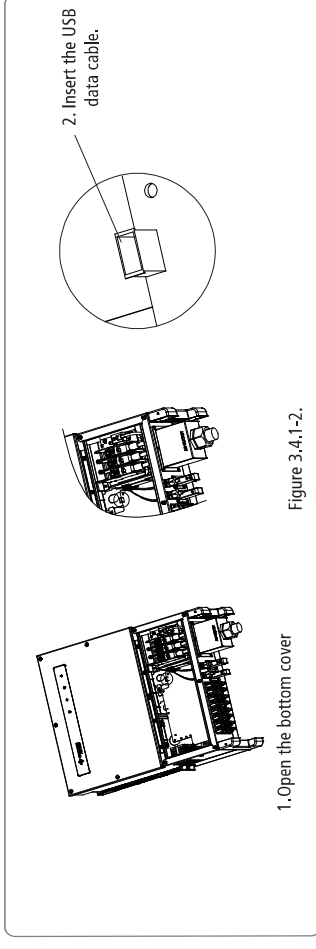
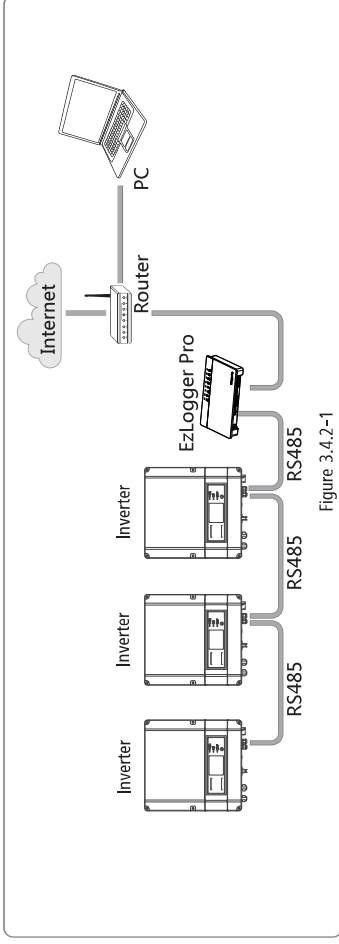

Figure 3.4.1-2.

If you need to use USB monitoring, please download the monitoring software EzExplorer from the official website.

3.4.2 RS485 Communication

This function is only applies to the inverter with RS485 ports. The RS485 port of inverter is used to connect the EzLogger Pro, and the total length of connecting cable should not exceed 1000m. Communication lines must be separated from other power lines to prevent the communication from being interfered. RS485 connection please refer to Figure 3.4.2-1.



The connection steps of RS485 communication of MT series are as follows:

- Remove the waterproof kit of RS485 cover with screwdriver.
- Remove the screw cap of the cable gland.
- Remove the one-hole sealing ring.
- Insert the RS485 cable through the components as the followings: screw cap, one-hole sealing ring, insulation body and sheetmetal parts.
- Fasten the cable as Figure 3.4.2 shown.
- Connect the compressed cable to the built-in communication interface of inverter.
- Fasten the RS485 waterproof kit to inverter.
- Fasten the screw cap of the cable gland.

Wire Size	Function
1	485_TX+
2	485_TX-
3	PE(Earth)
4	PE(Earth)
5	485_TX+
6	485_TX-

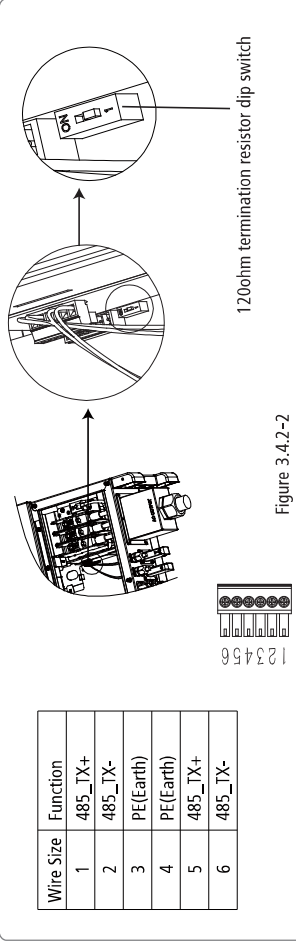

Caution

Cable requirements of RS485 communication: Shielded twisted-pair cable or shielded twisted-pair Ethernet cable 120ohm termination resistor is controlled by dip switch. "ON" means connected, and "OFF" means disconnected, illustrated as Figure 3.4.2-2. Selection mode of terminal resistance dial switch with 120ohm.

- When single inverter is in communication, dial the terminal resistance dial switch to ON state (The default is OFF) which is next to the RS485 communication port of inverter, so that the RS485 terminal is with 120ohm, and make the shielding layer of munication line single-point grounding, as shown in Figure 3.4.2-2.

- If multiple inverters are in communication, connect all the inverters in a daisy chain through the RS485 communication cable. For device at the end of daisy chain, dial the terminal resistance dial switch to ON state (The default is OFF), and make the shielding layer of communication line single-point grounding.

3.4.3 WiFi Communication

This function is only applicable for WiFi model. For specific configurations, please refer to WiFi Connection Configurations in the attachment, and you can also refer to the description of "Demo Videos of Monitoring Installation" on the <http://www.goodwe.com.cn/DownLoad.aspx> website.

After the configurations are completed, please register on the website <http://www.goodwe.com>.

Refer to WiFi app for specific configuration.

The WiFi module installation of MT series is shown in Figure 3.4.3-1.

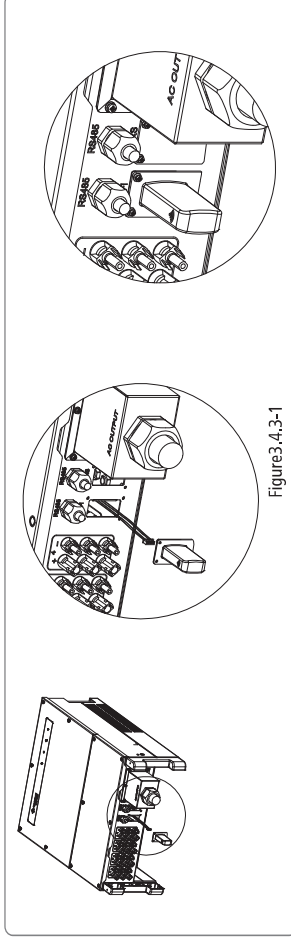

3.4.4 Earth Fault Alarm

The inverter complies with IEC62109-2 T3.9. When earth fault occurs, Buzzer in EzLogger Pro will ring for 1 minute, and RUN LED will be lighting for 1 minute. The alarm will ring again after half an hour unless the fault is resolved.

3.4.5 DRED

DRM function is achieved by EzLogger Pro, and please connect the EzLogger Pro through RS485 port. Detailed DRED connection refer to EzLogger Pro manual.

4 System Operation

4.1 Home Introduction

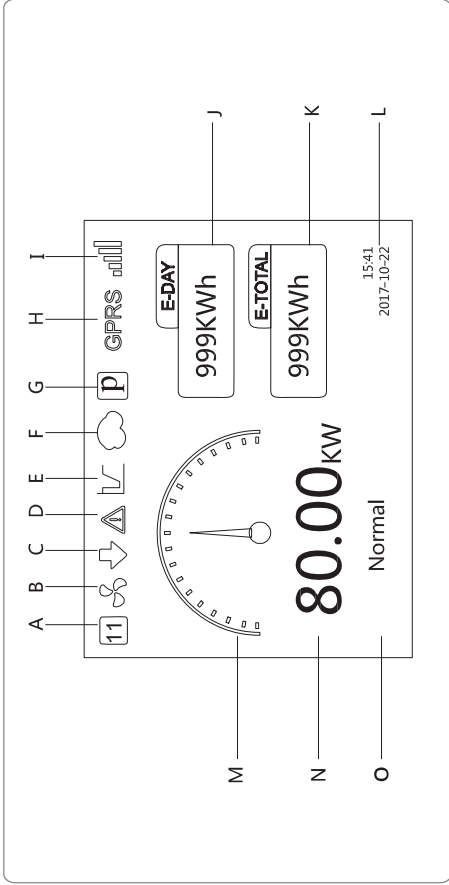

- A. Safety icon : The number represents the safety serial number
- B. Fan icon : The fan icon indicates that the fan is on and does not show that the fan is stopped
- C. Limited load icon : The display limit icon indicates that the system is limited
- D. Alarm icon : The alarm icon indicates that the system has an alarm message
- E. LVRT icon : The LVRT icon indicates that the system LVRT function is on
- F. Shadow icon : The Shadow icon indicates that the Shadow function is on
- G. PID icon : The PID icon indicates that the PID module exist
- H. Communication icon : The way of communication , There are three GPRS, WiFi and RS485
- I. Communication information icon : GPRS and WiFi show the signal strength, RS485 shows the communication address.
- J. E-Day icon : The total amount of electricity on that day
- K. E-Total : Historical cumulative power generation
- L. System time and date
- M. Real-time power icon
- N. Real-time power
- O. System status information

1. Overview of menu architecture

The display menu has a total of three levels, through the Up, Down, Enter, Esc key to operate the menu, which Enter key is divided into long press (greater than 3s) and short press, so a total of five key operation. Press the Enter Esc key to toggle the 123 menu, use the up and down keys to select the item and change the parameters, and press the Enter (greater than 3s) to set the parameters.

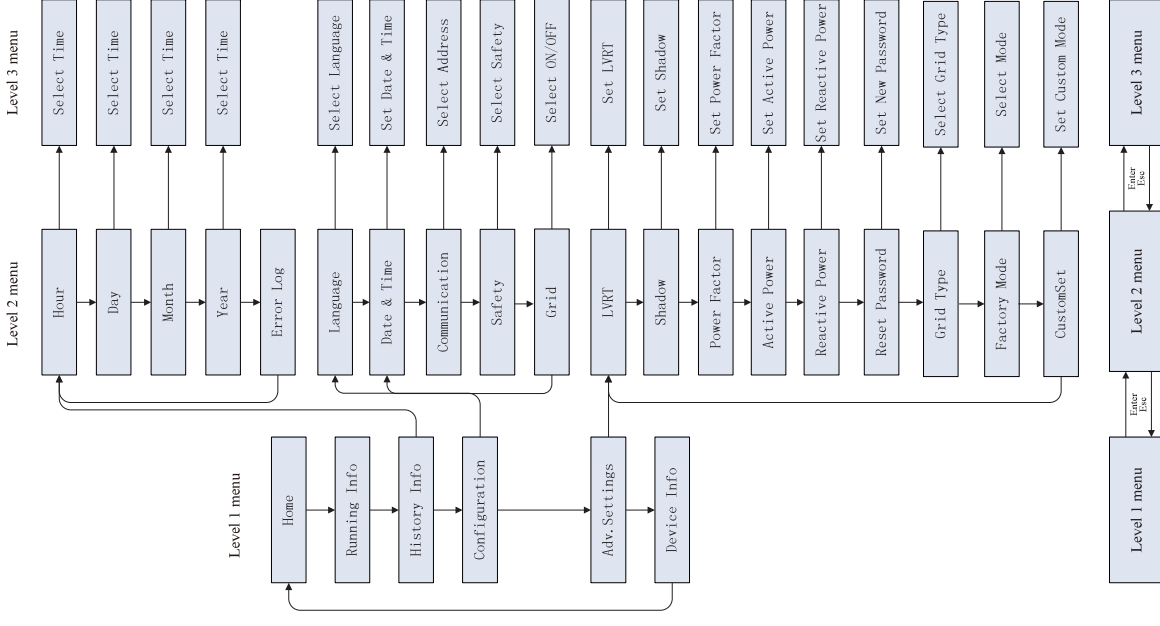

1.2 Level 1 menu

Level 1 menu interface through the up and down key cycle, in the historical information, configuration, advanced settings interface, press the Enter key will enter the Level 2 menu. To enter the Level 2 menu, select the item from the up and down keys. Press Enter to enter the project setup menu, go to the Level 3 menu, change the setting contents by pressing the up and down keys, and press the Enter key to set the contents. If safety country is not selected (shows "Configure Safety" on display at home page), press any key will enter Safety Country page.

1.4 Advanced Settings

Advanced settings are mainly used to set the function parameters of the equipment to running, in order to prevent the customer malfunction caused the device to run abnormal, all advanced settings items need to enter the password to obtain advanced settings permission to operate (enter a password you can set the advanced settings menu all the items). In order to prevent customers forgetting the password, all devices have a unique super password, the super password and SN binding. Advanced settings items include LVRT settings, Shadow settings, PF value settings, Active power settings, Reactive power settings and password modification settings five projects.

1.5 History Information

The history information mainly includes the information of the generating capacity of the equipment, the fault record, the power generation information mainly includes the amount of electricity generation, daily power generation, monthly power generation and annual power generation information.

1.3 Configuration

Configuration is mainly used to set the commonly used parameters, including language settings, time settings, communication settings and safety settings four projects.

(4) Menu introduction:

When PV panel is feeding power to the inverter, the screen shows the first interface of level 1 menu. The interface displays current state of the system. It shows 'Waiting' in the initial state; it shows 'Normal' during power generation mode; if there is something wrong with the system, error message is shown. Error code can be referred to figure 4.4.

- In the level 1 menu, the displayed information can be switched through 'DOWN' and 'UP' key operation, there are 6 interfaces in total, which are circulatory. The level 2 menu can only be selected through 'ENTER' from the seventh interface.
- In the level 2 menu, short press 'Error Log' to enter the historical error message interface, Press 'up' and 'down' to switch the display page and inquire the historical error message. Press 'Esc' to return.
- In the level 2 menu, short press 'Date&time' to enter the time setting interface, press 'up' and 'down' to change the data, short press 'Enter' to move cursor, long press 'Enter' to save the settings.
- You need to type in the password before enter the Advantage Setting, the inverter default password is 1111, you can set the parameters and modify the password after this password verification pass. If forget your password, please contact GoodWe after-sales for help.
- In the level 2 menu, choose 'Language' and press 'Enter' to enter language setting interface, press 'up' or 'down' to change language, long press 'Enter' to save the settings, press 'Esc' to return.
- In the level 1 menu, choose 'History Info', short press 'Enter' in turn to enter the level 2 and level 3 menu. In the level 3 menu, press 'up' or 'down' to inquire the historical power generation data in Year Mode, Month Mode, Day Mode and Hour Mode. Press 'Esc' back to upper menu.
- In the level 2 menu, short press 'Comm' to enter Modbus address interface. Press 'Up' or 'Down' to set the address, long press 'Enter' to save the address.

⚠ This function is used for special requirements, please don't set it arbitrarily.

- In the level 2 menu, select 'LVRT' (if LVRT mode has not been turned on), it will show 'OFF' on the right hand of LCD. Then press 'up' or 'Down' will change the state to 'ON'. Long press 'Enter' to save the setting and then display 'ON' after a while. LVRT mode has been successfully turned on.

⚠ This function is used for special requirements, please don't set it arbitrarily.

- In the level 2 menu, select 'Shadow' (if shadow mode has not been turned on), it will show 'OFF' on the right hand of LCD. Then press 'up' or 'Down' will change the state to 'ON'. Long press 'Enter' to save the setting and then display 'ON' after a while. Shadow mode has been successfully turned on.

⚠ This function is used for special requirements, please don't set it arbitrarily.

- Select 'Safety' in the 'Configuration' menu, then press 'Enter' and there will be set safety interface. Press 'Down' or 'Up' to choose the safety you need and then long press 'ENTER', the chosen safety will be set. If there is no EXACTLY proper country code, please choose '50Hz Grid Default' or '60Hz Grid Default' accordingly.

4.2 Wi-Fi Reset & Wi-Fi Reload

1. Choose 'Wi-Fi Reset' in level 3, press 'Enter' for 3 seconds to reset inverter Wi-Fi modular; wait for a while, operation result will show on display, the function can be applied when inverter is unable to connect to router or monitor server.
2. Choose 'Wi-Fi Reload' in level 3, press 'enter' button for 3 seconds, The initial setting of Wi-Fi modular will be reload. Wait for a while, operation result will show on display, the function can be applied when inverter is unable to connect to Wi-Fi modular. Once Wi-Fi modular restore initial setting, Wi-Fi modular need be reset again.

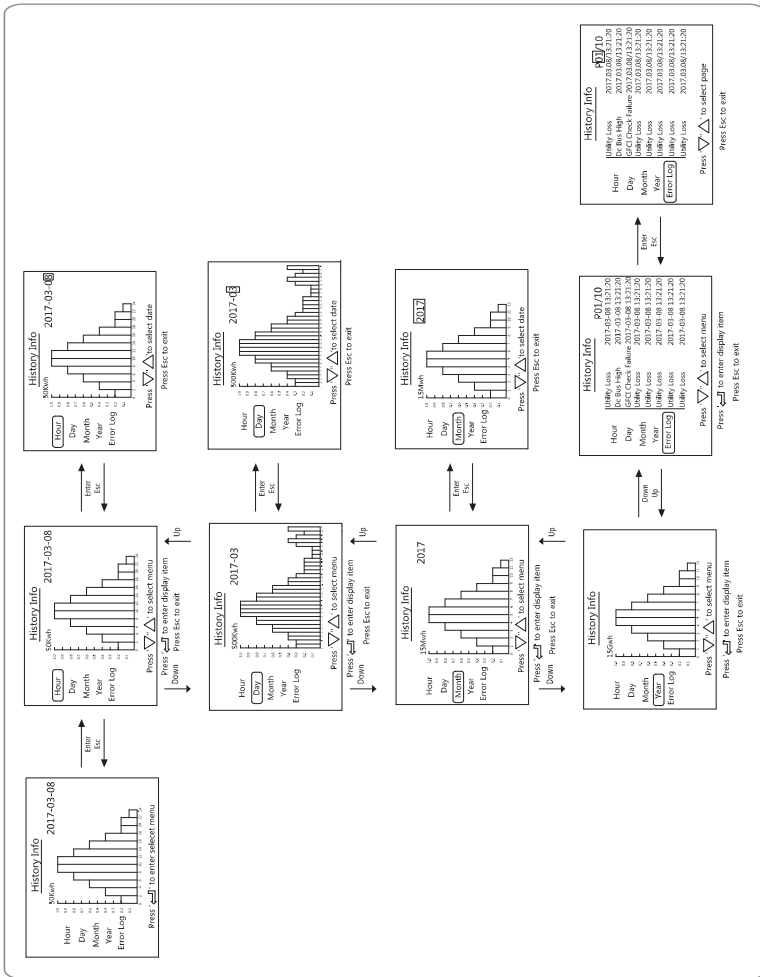

1.6 Operation of Display when start up.

When the input voltage reaches inverter turn-on voltage, LCD displays 'waiting'. If the grid is accessible, 'Checking xxx Sec' (The time is decided by the grid connection standards from different country) will be shown up in 5sec. During the counting, the inverter is self-checking, when it shows '00Sec' you can hear the sound from the motion of the relay. LCD displays 'Normal' afterwards. The instant power output will be shown at the left of LCD.

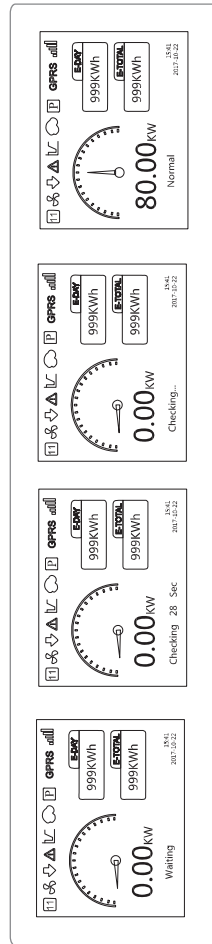



Notice : This function is only applies to the inverter equipped with Wi-Fi modular .

4.3 system operation

1. Make sure the AC circuit is connected and AC breaker is turned off.
2. Make sure the DC cable between inverter and PV string is connected, and the PV voltage is normal
3. Turn on the DC switch, and set safety according to the local regulation.
4. Turn on the AC breaker. Check the inverter work normal.

4.4 Error code

The error message in below diagram will be displayed on the LCD if a fault occurs.

Error code	Error message	Description
01	SPI Failure	Internal communication failure
02	EEPROM R/W Failure	Memory chip failure
03	Fac failure	Grid Frequency exceed the inverter limit
07 , 25	Relay Check Failure	Relay self-checking failure
12	LCD Communication Failure	Communication error occurs between LCD DSP and the Master DSP.
13	DC Injection HlGH	The DC component of AC current exceed inverter limit
14	Isolation Failure	Insulation Resistance between the ground and the panel is too low
15	Vac Failure	Grid voltage exceed the inverter limit
16	External FAN Failure	External Fan Failure
17	PV OVER Voltage	PV Array voltage is exceed the inverter limit
19	OVER Temperature	Over temperature on the case
20	IFAN Fault	Internal FAN Failure
21	DC BUS HIGH	BUS voltage over high
22	Ground I Failure	Residual current protection
23	Utility Loss	Grid disconnection/fault
30	REF 1.5V Failure	1.5V reference voltage exceeds the limit
31 , 24	AC HCT Failure	AC current sensor failure
32 , 26	GFCI Failure	Leakage current detection circuit Failure.
Others	Device Failure	Internal Device Failure

4.11 Special Adjustable Setpoints

The inverter has field adjustable function,such as trip points,trip times, reconnect times,active and invalid of QU curve,PU curve. It is adjustable through special software ,if you want to use it ,please contact with after sales. The methods document of using the software can download from goodwe website or contact with after sales.

5 Troubleshooting

If the inverter is not able to work properly, please refer to the following instructions before contact your local service. Should any problems arise, the red (FAULT) LED indicator on the front panel lights up and the LCD screen will display relevant information. Please refer to the following table for a list of error message and associated solutions.

Type of Fault	Trouble shooting
Isolation Failure	1. Check the impedance between Ground and PV (+) & PV (-), The impedance value must be greater than 100KΩ, make sure the inverter is earthed. 2. Contact local service office for help if the problem still exists.
Ground I Failure	1. The ground current is too high. 2. Unplug the inputs from the PV generator and check the peripheral AC system. 3. When the problem is cleared, reconnect the PV panel and check the Inverter status. 4. Contact local service office for help, if the problem still exists.
Vac Failure	1. The PV Inverter will automatically restart within 5 minutes if the grid returns to normal. 2. Make sure grid voltage is in conformity with the specification. 3. Make sure Neutral (N) Wire and PE wire is connected well. 4. Contact local service office for help, if the problem still exists.
Fac Failure	1. Grid is not connected. 2. Check grid connection cables. 3. Check availability of grid
Utility Loss	1. Not connect to the grid 2. Check that the power grid is connected to cable. 3. Check the availability of power grid.
PV over voltage	1. Check the PV open circuit voltage is higher or too close to the maximum input voltage or not. 2. If the problem still exists when PV voltage is less than the maximum input voltage, contact local service office for help.
Over Temperature	1. The internal temperature is higher than normal value specified. 2. Reduce ambient temperature. 3. Move the inverter to a cool place. 4. If the problem still exists, contact local service office for help.
Relay-Check Failure	
DC Injection High	
EEPROM R/W Failure	
SCI Failure	
SPI Failure	1. Turn off DC switch of the inverter. 2. Wait till inverter LCD unlighted.
DC Bus High	3. Turn on DC switch and make sure it connected.
BUS Unbalance	4. If the problem still exists, contact local service office for help.
GFCI Failure	
Ifan Fault	
Efan Fault	
Afan Fault	
No display	1. Turn off DC switch, take off DC connector, measure the voltage of PV array. 2. Plug in DC connector, and turn on DC switch. 3. If PV array voltage is lower than 250V , please check configuration of invert module. 4. If voltage is higher than 250V , please contact local office.

Notice: When sunlight is insufficient, the PV Inverter may continuously start up and shut down automatically due to insufficient power generated by the PV panel.

5.1 Overvoltage category definition

Category I : applies to equipment connected to a circuit where measures have been taken to reduce transient overvoltage to a low level.

Category II : applies to equipment not permanently connected to the installation. Examples are appliances, portable tools and other plug-connected equipment;

Category III: applies to fixed equipment downstream of and including, the main distribution board. Examples are switchgear and other equipment in an industrial installation;

Category IV: applies to equipment permanently connected at the origin of an installation (upstream of the main distribution board). Example are electricity meters, primary overcurrent protection equipment and other equipment connected directly to outdoor open lines.

5.2 Moisture location category definition

Moisture parameters	Level	
Temperature range	3K3 0~+40°C	4K2 -33~+40°C
Humidity range	5% ~85%	4K4H -20~ +55°C 15% ~ 100% 4% ~100%

5.3 Environment category definition

Outdoor : the ambient air temperature is -20~50°C, Relative humidity range is 4 % to 100 %, applied to PD3.

Indoor unconditioned: the ambient air temperature is -20~50°C, Relative humidity range is 5 % to 95%, applied to PD3.

Indoor conditioned: the ambient air temperature is 0~40°C, Relative humidity range is 5 % to 85%, applied to Pd2.

5.4 Pollution degree definition

Pollution degree 1: No pollution or only dry, non-conductive pollution occurs. The pollution has no influence.

Pollution degree 2: Normally only non-conductive pollution occurs. Occasionally, however, a temporary conductivity caused by condensation must be expected.

Pollution degree 3: Conductive pollution occurs, or, dry, non-conductive pollution occurs which becomes conductive due to condensation which is expected.

Pollution degree 4: Persistent conductive pollution occurs, for example, the pollution cause by conductive dust, rain and snow.

6 Technical parameters and block diagram

6.1 Technical parameters

Name	Name	GW50K-MT	GW60K-MT	GW50KN-MT	GW60KN-MT	GW50KBF-MT	
DC Input Data	Max. PV Power(W)	65000	80000	65000	80000	65000	
	Max. DC Input Voltage (V)	1000	1000	1100	1100	1100	
	MPPT Range (V)	200~850	200~850	200~1000	200~1000	200~1000	
	Starting Voltage (V)	200	200	200	200	200	
	MPPT Range for Full Load (V)	520~850	520~850	520~850	520~850	450~850	
	Nominal DC Input Voltage (V)	620	620	620	620	620	
	Max. Input Current (A)	30/30/20/20	30/30/30/30	33/33/22/22	33/33/33/33	30/30/30/30	
	Max. Short Current (A)	38/38/25/25	38/38/38/38	41.5/41.5/27.5/27.5	41.5/41.5/41.5/41.5	37.5/37.5/37.5/37.5	
	No. of MPP Trackers	4	4	4	4	4	
	No. of Input Strings per Tracker	3/3/2/2	3/3/3/3	3/3/2/2	3/3/3/3	2/2/2/2	
AC Output Data	Nominal Output Power (W)	50000	60000	50000	60000	50000	
	Max. Output Power (W)	55000;57500@415Vac	66000;69000@415Vac	55000;57500@415Vac	66000;69000@415Vac	55000;57500@415Vac	
	Max. Output Apparent Power (VA)	55000;57500@415Vac	66000;69000@415Vac	55000;57500@415Vac	66000;69000@415Vac	55000;57500@415Vac	
	Nominal Output Voltage (V)	400, 3L/N/PE or 3L/PE	400, 3L/N/PE or 3L/PE	400, 3L/N/PE or 3L/PE	400, 3L/N/PE or 3L/PE	400, 3L/N/PE or 3L/PE	
	Nominal Output Frequency (Hz)	50/60	50/60	50/60	50/60	50/60	
	Max. Output Current (A)	80	96	80	96	80	
	Output Power Factor	-1 (Adjustable from 0.8 leading to 0.8 lagging)					
	Output THD (@Nominal Output)	<3%					
	Efficiency	Max. Efficiency	98.7%	98.8%	98.7%	98.8%	98.8%
		Euro Efficiency	98.3%	98.5%	98.3%	98.5%	98.3%
MPPT Efficiency		99.9%	99.9%	99.9%	99.9%	99.9%	
Protection	PV String Current Monitoring	Integrated					
	Anti-islanding Protection	Integrated					
	Input Reverse Polarity Protection	Integrated					
	Insulation monitoring	Integrated					
	DC fuse	Integrated					
	Anti-PID Function for Module	Optional					
	DC SPD Protection	Integrated (Type II)					
	AC SPD Protection	Integrated (Type II)					
	Residual Current Monitoring Unit	Integrated					
	AC Over Current Protection	Integrated					
AC Short Protection	Integrated						
AC Over Voltage Protection	Integrated						

Name	GW50K-MT	GW60K-MT	GW50KN-MT	GW60KN-MT	GW50KBF-MT	
Ambient Temperature Range (°C)	-30~60					
Relative Humidity	0~100%					
Operating Altitude (m)	≤4000					
Cooling	Fan Cooling					
Display	LCD or WiFi+APP					
Communication	RS485 or WiFi or PLC					
Weight (kg)	59kg	64kg	59kg	64kg	59kg	
Dimension (Width*Height*Depth:mm)	586*788*264					
Protection Degree	IP65					
Night Self Consumption (W)	<1					
Topology	Transformerless					
Certifications & Standards	IEC61727, IEC62116, VDE4105, VDE0126, RD1699, RD413, RD661, EN61438, AS/NZS 4772.1, NRS 107, CEI 0-21, ERD-A0-RES_13E, MEA, PEA	IEC61727, IEC62116, VDE4105, VDE0126, RD1699, RD413, RD661, EN61438, AS/NZS 4772.1, NRS 107, CEI 0-21, ERD-A0-RES_13E, MEA, PEA	IEC61727, IEC62116, VDE4105, VDE0126, RD1699, RD413, RD661, EN61438, AS/NZS 4772.1, NRS 107, CEI 0-21, ERD-A0-RES_13E, MEA, PEA	IEC61727, IEC62116, VDE4105, VDE0126, RD1699, RD413, RD661, EN61438, AS/NZS 4772.1, NRS 107, CEI 0-21, ERD-A0-RES_13E, MEA, PEA	IEC61727, IEC62116, VDE4105, VDE0126, RD1699, RD413, RD661, EN61438, AS/NZS 4772.1, NRS 107, CEI 0-21, ERD-A0-RES_13E, MEA, PEA	IEC61727, IEC62116, VDE4105, VDE0126, RD1699, RD413, RD661, EN61438, AS/NZS 4772.1, NRS 107, CEI 0-21, ERD-A0-RES_13E, MEA, PEA
	IEC62108-1/2	IEC62108-1/2	IEC62108-1/2	IEC62108-1/2	IEC62108-1/2	
	EN 61004-6-4; 2007+A1:2011, EN 61000-6-2:2005, EN 61000-3-11:2000, EN 61000-3-12:2011+AC:2013	EN 61004-6-4; 2007+A1:2011, EN 61000-6-2:2005, EN 61000-3-11:2000, EN 61000-3-12:2011+AC:2013	EN 61004-6-4; 2007+A1:2011, EN 61000-6-2:2005, EN 61000-3-11:2000, EN 61000-3-12:2011+AC:2013	EN 61004-6-4; 2007+A1:2011, EN 61000-6-2:2005, EN 61000-3-11:2000, EN 61000-3-12:2011+AC:2013	EN 61004-6-4; 2007+A1:2011, EN 61000-6-2:2005, EN 61000-3-11:2000, EN 61000-3-12:2011+AC:2013	EN 61004-6-4; 2007+A1:2011, EN 61000-6-2:2005, EN 61000-3-11:2000, EN 61000-3-12:2011+AC:2013

Name	GW70KHV-MT	GW60KBF-MT	GW80KBF-MT	GW80KHV-MT
Max. PV Power(W)	91000	80000	104000	120000
Max. DC Input Voltage (V)	1100	1100	1100	1100
MPPT Range (V)	200~1000	200~1000	200~1000	200~1000
Starting Voltage (V)	200	200	200	200
MPPT Range for Full Load (V)	550~850	400~850	540~850	500~850
Nominal DC Input Voltage (V)	750	620	800	800
Max. Input Current (A)	33/33/33/33	39/39/39/39	39/39/39/39	44/44/44/44
Max. Short Current (A)	41.5/41.5/41.5/41.5	55/55/55/55	54.8/54.8/54.8/54.8	55/55/55/55
No. of MPP Trackers	4	4	4	4
No. of Input Strings per Tracker	3/3/3/3	3/3/3/3	3/3/3/3	4/4/4/4
Nominal Output Power (W)	70000	60000	80000	80000
Max. Output Power (W)	77000	66000@415V/ac	88000	88000
Max. Output Apparent Power (VA)	77000	66000@415V/ac	88000	88000
Nominal Output Voltage (V)	500, 3L/PE	400, 3L/PE 或 3L/PE	540, 3L/PE	540, 3L/PE
Nominal Output Frequency (Hz)	50/60	50/60	50/60	50/60
Max. Output Current (A)	89	96	94.1	94.1
Output Power Factor	~1 (Adjustable from 0.8 leading to 0.8 lagging)			
Output THD (@Nominal Output)	<3%			

Name	GW70KHV-MT	GW60KBF-MT	GW80KBF-MT	GW80KHV-MT
Max. Efficiency	99.0%	98.8%	99.0%	99.0%
Euro Efficiency	98.4%	98.3%	98.4%	98.4%
MPPT Efficiency	99.9%	99.9%	99.9%	99.9%
PV String Current Monitoring	Integrated			
Anti-islanding Protection	Integrated			
Input Reverse Polarity Protection	Integrated			
Insulation monitoring	Integrated			
DC Fuse	Integrated			
Anti-PID Function for Module	Optional			
DC SPD Protection	Integrated (Type II)			
AC SPD Protection	Integrated (Type II)			
Residual Current Monitoring Unit	Integrated			
AC Over Current Protection	Integrated			
AC Short Protection	Integrated			
AC Over Voltage Protection	Integrated			
Ambient Temperature Range (°C)	-30~60			
Relative Humidity	0~100%			
Operating Altitude (m)	≤4000			
Cooling	Fan Cooling			
Display	LCD or WiFi+APP	WiFi+APP		
Communication	RS485 or WiFi or PLC			
Weight (kg)	60kg	72kg	72kg	72kg
Dimension (Width*Height*Depth:mm)	586*788*264			
Protection Degree	IP65			
Night Self Consumption (W)	<1			
Topology	Transformerless			
Certifications & Standards	IEC61727, IEC62116, VDE4105, VDE0126, RD1699, RD413, RD661, EN61438	IEC61727, IEC62116, VDE4105, VDE0126, RD1699, RD413, RD661, EN61438	IEC61727, IEC62116, VDE4105, VDE0126, RD1699, RD413, RD661, EN61438	IEC61727, IEC62116, VDE4105, VDE0126, RD1699, RD413, RD661, EN61438
	IEC62108-1/2	IEC62108-1/2	IEC62108-1/2	IEC62108-1/2
Safety Regulation	EN 61004-6-4; 2007+A1:2011, EN 61000-6-2:2005, EN 61000-3-11:2000, EN 61000-3-12:2011+AC:2013			
EMC Regulation	EN 61004-6-4; 2007+A1:2011, EN 61000-6-2:2005, EN 61000-3-11:2000, EN 61000-3-12:2011+AC:2013			

6.2 Block Diagram

GW50K-MT&GW50KN-MT main circuit is shown in Figure 6.2-1

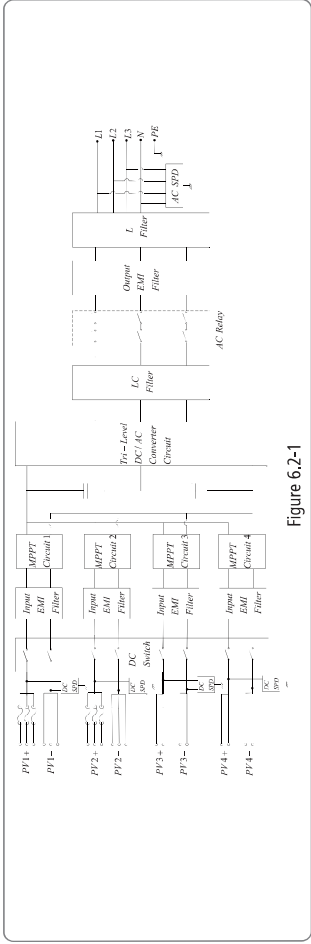

Figure 6.2-1

GW50KBF-MT main circuit is shown in Figure 6.2-2

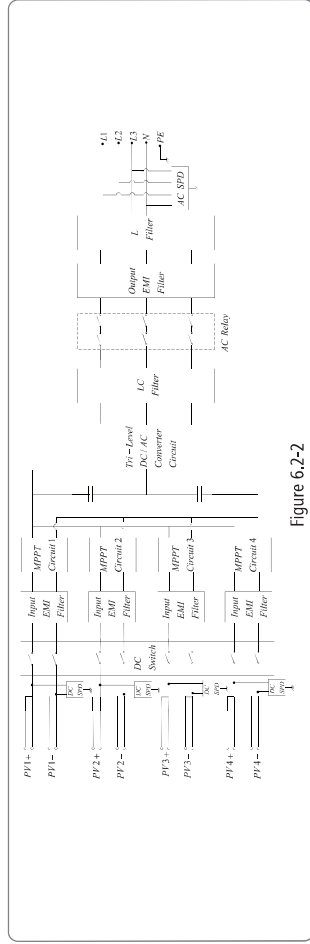

Figure 6.2-2

GW60K-MT&GW60KN-MT&GW60KBF-MT main circuit is shown in Figure 6.2-3

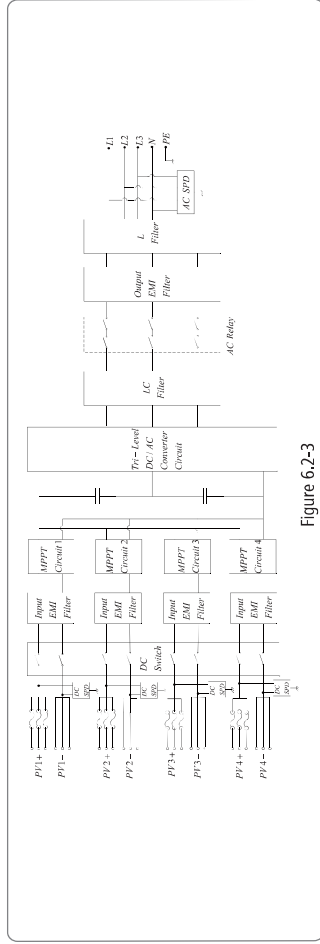

Figure 6.2-3

GW70KHV-MT&GW80KBF-MT main circuit is shown in Figure 6.2-4

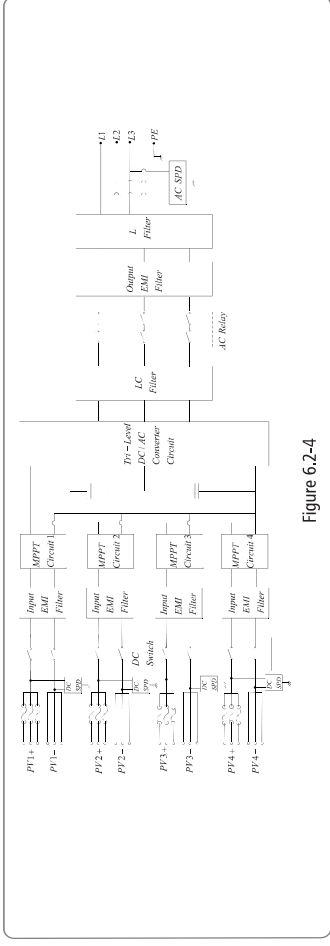

Figure 6.2-4

GW80KHV-MT main circuit is shown in Figure 6.2-5

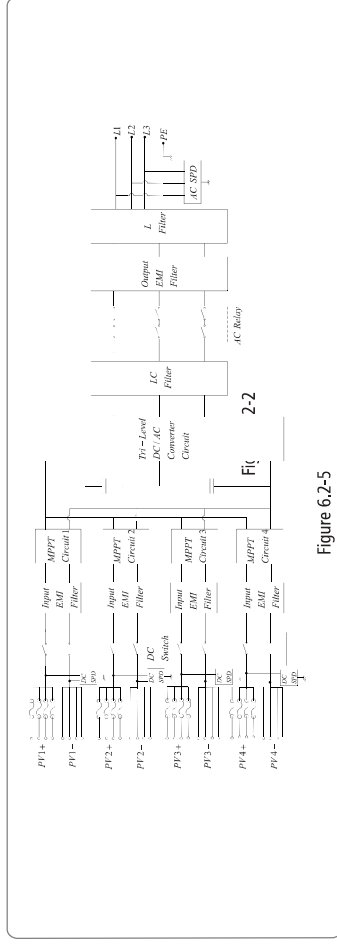

Figure 6.2-5

7 Maintenance

Regular maintenance ensures a long operating life and optimal efficiency of the entire PV plant.

Caution: Before maintaining, please disconnect the AC breaker firstly and then disconnect DC breaker. Wait 5 minutes until the residual voltage has been released.

7.1 Clearing the FAN

MT series inverter is equipped with three fans on its left side. The fan intakes and handle covers should be cleaned yearly with a vacuum cleaner. For more thorough cleaning, completely remove the fans.

- Disconnect the AC breaker firstly and then disconnect DC breaker.
- Wait 5 minutes until the residual voltage has been released and the fans are no longer turning.
- Disassembly the fans (refer to Figure 7.1-1).

(1) Loosen the five screws with a crosshead screwdriver, then remove the fans out the cabinet about 50mm slowly.

(2) Open the lockers of the three fans connectors and remove them from housing, then take the fans away.

- Clean the ventilation grid and the fan with a soft brush, a paint brush, a cloth, or compressed air.
- Reassembly the out fans into cabinet.

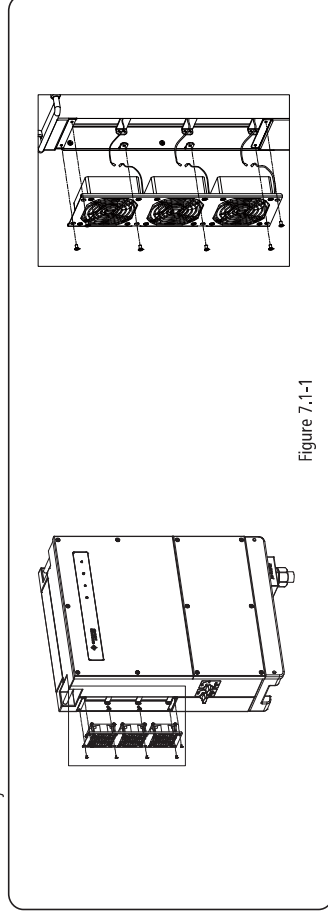

Figure 7.1-1

7.2 Checking the DC Switch

DC switch does not require any maintenance.

It is recommended, though not compulsory, to:

- Check the DC switch regularly.
- Activate the DC switch 10 times in a row once a year.

Operating the switch will clean the contacts and will extend the life of the DC switch.

Boot order:

1. Turn on the breaker on AC side.
2. Turn on the DC switch.
3. Turn on the breaker on DC side.

Caution: if there is no switch, operate from step1 to step 3.

shutdown order:

1. Turn off the breaker on AC side.
2. Turn off the DC switch.
3. Turn off the breaker on DC side.

Caution: if there is no switch, operate from step1 to step 3.

7.3 Checking the Electrical Connection

1. Check if the AC or DC wire is loose.
2. Check if the earth wire is reliable grounding.
3. Check if the waterproof covers of RS485 and USB port is fasten.

Caution: Maintenance cycle is once half a year.

7.4 Fuse Replacement

If the inverter fuses are broken, replace them in time, the steps are as follows:

1. Disconnect the circuit breaker on the AC side;
2. Rotate the DC switch to the "OFF" position;
3. Disconnect the front-end circuit breaker of PV input terminal or pull out the PV input terminal;
4. Wait for at least 10 minutes;
5. Open the junction box cover on the bottom of inverter;
6. Confirm that the fuses are broken;
7. Remove the broken fuses on vertical direction which is shown in the right figure, and don't remove fuses with prying method, etc;
8. Install the fuses of the same company and model to the corresponding fuse holders;

Install the junction box cover on the inverter.

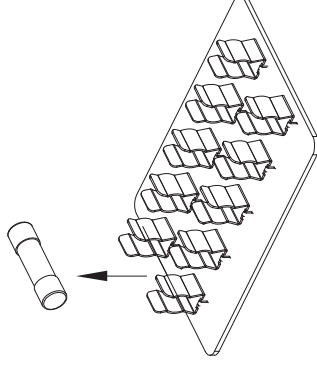

8 Relevant Certification



PEA

VDE-AR-N 4105

IEC62109-2

EN50438